



# CEMENT MIXA

AUSTRALIA'S PREMIER ATTACHMENT MANUFACTURER



## Cement Mixa

Digga Cement Mixa can mix anything from cement to fertilizer, it fits quickly and easily to your Digga Planetary Auger Drive (Auger Drive sold separately)

### Features:

- Simple efficient design requires minimal fitment and can be fitted to your SCS
- Cement mixing attachment to suit all premium Digga auger drives and Mini Auger Drives
- Maintenance free
- New Design, easy connection

### Ideal Use:

Mixing cement, fertilizer

### Machine Suitability:

Skid Steer Loaders, Front End Loaders and Tele-Handlers.

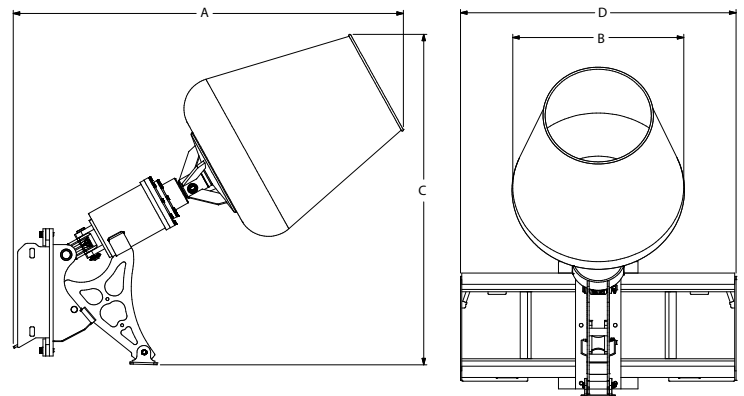

Specifications	2.2 cubic feet	3.5 cubic feet
Length (A)	1300 mm	1424 mm
Width (B)	1212 mm	1212 mm
Height (C)	1469 mm	1571 mm
Width (D) Bowl Only	580 mm	740mm
Max Flow (LPM)	30-75	75-230
Max Pressure (Bar)	205	240
Weight	397kgs	422kgs
Weight (bowl only)	17.5kgs	26kgs

# GET ATTACHED

*with an experienced partner*

#### DIGGA Head Office

##### Brisbane QLD

4 Octal Street,  
Yatala QLD 4207  
Ph: (07) 3807 3330  
Fax: (07) 3807 1499

Email: [info@digga.com](mailto:info@digga.com) Web: [www.digga.com](http://www.digga.com)

#### DIGGA NSW

1 Gallipoli St, Smeaton  
Grange, NSW, 2567  
Ph: (02) 4647 1400  
Fax: (02) 4647 1433

#### DIGGA VIC

21 - 25 Villas Road  
Dandenong VIC, 3175  
Ph: (03) 9706 6171  
Fax: (03) 9706 6164

#### DIGGA WEST

13 Yampi Way,  
Willetton, WA, 6155  
Ph: (08) 9457 1544  
Fax: (08) 9457 0748

